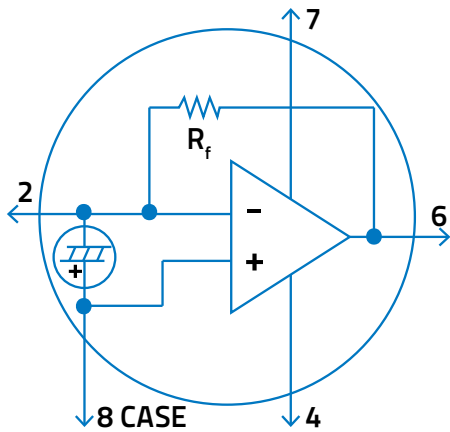


# APPLICATION NOTE

## QS DETECTORS PIN-OUTS AND DESCRIPTIONS

### QS-IL, QS-IF AND QS-THZ HYBRID PYROELECTRIC DETECTORS



**Figure 1:** QS-IL, QS-IF and QS-THZ Pin-Out

### PIN-OUT

These three families of Hybrid Pyroelectric Detectors include a  $\text{LiTaO}_3$  detector element, a low noise Current Mode op amp and a large feedback resistor. The QS-IL and QS-THZ are designed for optimum  $R_V$  and NEP at 5 Hz. The QS-IF incorporates a high bandwidth op amp and a slightly smaller feedback resistor for flat voltage output up to 1000 Hz.

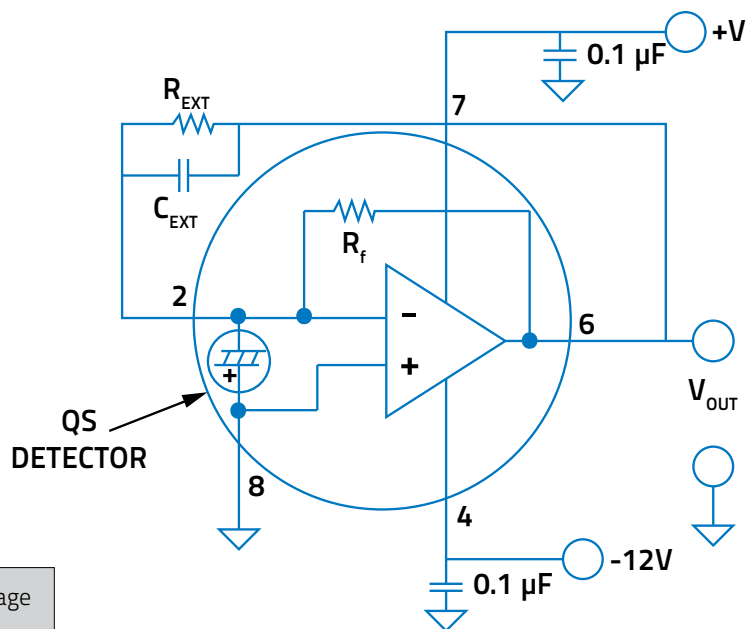
The three series share the same Pin-Out, as shown in Fig. 1. Note that Pins 1, 3, and 5 are not connected inside the TO package and therefore are not part of the electronics.

**CAUTION:** Please review our Application Note 202181 on Handling Sensitive Pyro Detectors.

### SCHEMATIC OF OPERATION

The circuit on Fig. 2 shows the typical connections made to the hybrid detector. +/- 12 V powers the op amp. You can add an external feedback resistor to increase the bandwidth of the detector and/or lower the voltage responsivity. We recommend cutting pin 2 off if there is no plan to use an external component. This way, the detector's performance will be optimized.

**CAUTION:** Make sure to apply the +Voltage to PIN 7 and -Voltage to PIN 4 to avoid damaging the op amp circuit.



**Figure 2:** QS-IL, QS-IF and QS-THZ circuitry

# APPLICATION NOTE

## QS-VL HYBRID PYROELECTRIC DETECTORS

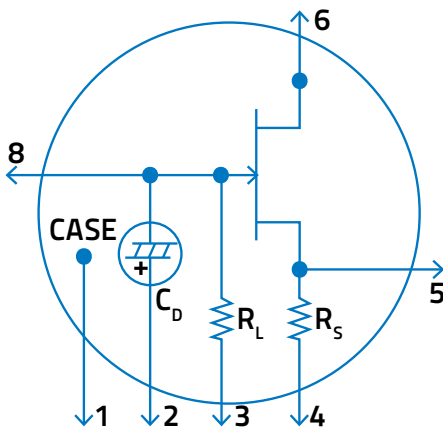


Figure 3: QS-VL Pin-Out

### PIN - OUT

This family of Hybrid Pyroelectric Detectors includes a  $\text{LiTaO}_3$  detector element, a low noise FET Voltage Mode preamp and a large feedback resistor. The QS-VL detectors are designed for optimum  $R_V$  and NEP at 5 Hz.

The Pin-Out is shown in Fig. 3. Note that Pin 7 is not connected inside the TO package and therefore is not part of the electronics.

**CAUTION:** Please review our Application Note 202181 on Handling Sensitive Pyro Detectors.

### SCHEMATIC OF OPERATION

The circuitry on Fig. 4 shows the typical connections made to the hybrid detector in a source follower circuit. You can add an external Load Resistor between Pin 8 and GND. This effectively allows you to change the voltage responsivity and/or the bandwidth of the detector.

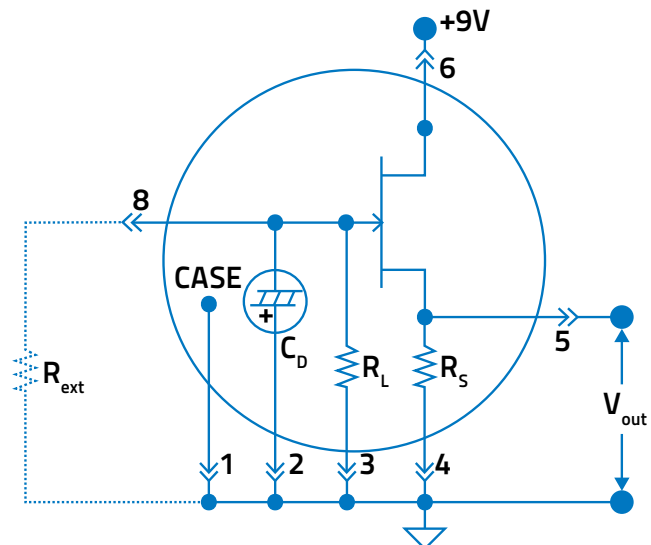
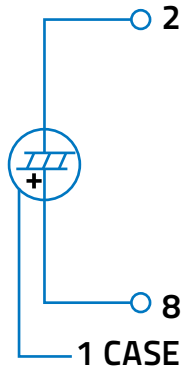


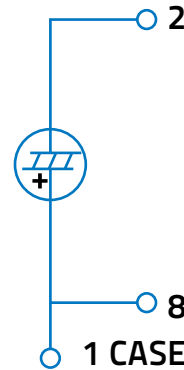
Figure 4: QS-VL circuitry

# APPLICATION NOTE

## QS-L AND QS-H DISCRETE PYROELECTRIC DETECTORS

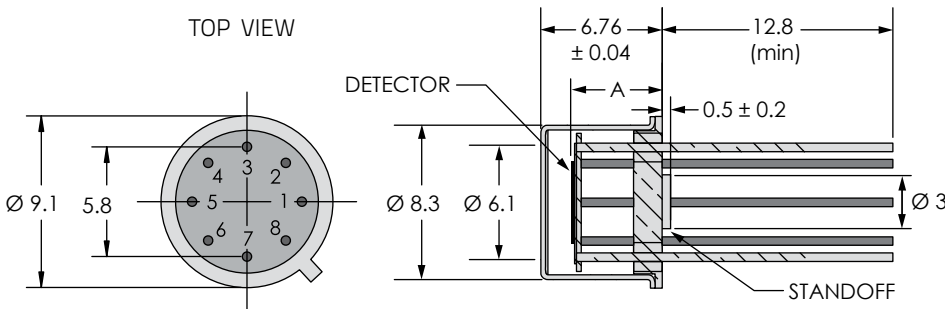


**Figure 5:** QS-L Pin-Out



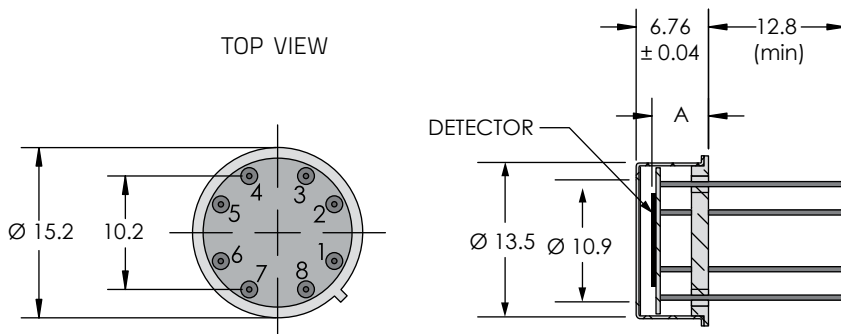
**Figure 6:** QS-H Pin-Out

## MECHANICAL DETAILS OF THE QS DETECTORS



**Figure 7:** QS detectors mechanical details (TO5-Based)

MODEL	DIM. A
QS-L	4.6
QS-H	2.0
QS-VL	4.6
QS-IF	4.6
QS-IL	4.6



**Figure 8:** QS detectors mechanical details (TO8-Based)

MODEL	DIM. A
QS-L	4.6
QS-H	2.0
QS-VL	4.6
QS-IF	4.6
QS-IL	4.6