



# USER MANUAL

QE Series | Pyroelectric Energy Detectors

All Gentec-EO products carry a one-year warranty from the date of shipment on material or workmanship defects when used under normal operating conditions.

Gentec-EO will repair or replace, at its sole discretion, any product that proves to be defective during the warranty period.

The warranty does not cover damages caused by product misuse, product modifications, accidents, abnormal operating or handling conditions, or third-party battery leakage. Any attempt by an unauthorized person to alter or repair the product voids the warranty. Gentec-EO is not liable for consequential damages of any kind.

## CLAIMS

For warranty service, please contact your Gentec-EO representative or fill out an RMA request:

<https://www.gentec-eo.com/contact-us/support-rma-request>

To help us answer your request more efficiently, please have your product serial number ready before contacting customer support.

Upon receipt of return authorization, ship the product according to the RMA instructions. Do not ship items without a return authorization. Transport is at the customer's expense, in both directions, unless the product has been received damaged or non-functional. Gentec-EO assumes no responsibility for the damage caused in transit.

## TABLE OF CONTENTS

1.	QE SERIES ENERGY DETECTORS.....	4
1.1.	Included with your QE .....	4
1.2.	Introduction.....	4
1.3.	Product name structure.....	5
1.4.	Absorbers .....	5
1.4.1.	MB: General use, broadband absorber.....	5
1.4.2.	MT: Absorber for high repetition rates.....	5
1.4.3.	QED: Diffusing attenuator for high energy density .....	5
1.4.4.	BL: Low noise, flat spectral response.....	5
1.4.5.	Absorptance curves for all absorbers .....	6
1.5.	Connectors and all-in-one meters.....	6
1.5.1.	“Smart” DB15 connector .....	6
1.5.2.	INT: Integra all-in-one meter with USB connector .....	7
1.5.3.	INE: Integra all-in-one meter with USB connector and external trigger .....	7
1.5.4.	IDR: Integra all-in-one meter with RS232 connector .....	7
1.5.5.	Custom connectors .....	7
1.6.	Specifications .....	9
1.6.1.	Footnotes .....	9
1.6.2.	QE12-MB.....	10
1.6.3.	QE12-MT .....	11
1.6.4.	QE25-MB.....	12
1.6.5.	QE25-MT .....	13
1.6.6.	QE50-MB.....	14
1.6.7.	QE50-MT .....	15
1.6.8.	QE65-MB.....	16
1.6.9.	QE95-MB.....	17
1.6.10.	QE8-B.....	19
1.6.11.	QE4-MT .....	20
1.6.12.	QED attenuators.....	21
2.	OPERATING INSTRUCTIONS.....	22
2.1.	Safety .....	22
2.2.	When used with a compatible monitor .....	22
2.2.1.	General instructions .....	22
2.2.2.	Working at wavelengths other than 1.064 $\mu$ m (except with QED attenuator) .....	23
2.3.	Using an oscilloscope .....	23
2.3.1.	General instructions .....	23
2.3.2.	Working at other wavelengths than 1.064 $\mu$ m .....	24
3.	DAMAGE TO THE OPTICAL ABSORBER MATERIALS.....	25
4.	DECLARATION OF CONFORMITY.....	26
5.	UKCA DECLARATION OF CONFORMITY .....	27
	APPENDIX A: QED ATTENUATOR CALIBRATION PROCEDURE .....	28
	When using an oscilloscope .....	28
	When using a Gentec-EO monitor.....	28
	Procedure .....	28
	APPENDIX B: WEEE DIRECTIVE .....	29

## 1. QE SERIES ENERGY DETECTORS

### 1.1. INCLUDED WITH YOUR QE

The following items are included with QE series laser energy detectors:

Description	Part name	Part number
QE series energy detector		
Protective cover		
Calibration certificate		
"Personal wavelength correction™" certificate		
Test target (QE-MB and QE-MB-QED models only)		

The following items can be purchased separately:

Description	Part name	Part number
Stand recommended for smaller models (for QE12, QE25 and QE50 series)	STAND-D-233	200428
Stand recommended for larger models (for QE65 and QE95 series)	STAND-D-443	201284
Attenuator for QE12 series	QED-12	201200
Attenuator for QE25 series	QED-25	201199
Attenuator for QE50 series	QED-50	201198
Attenuator for QE65 series	QED-65	201282
Attenuator for QE95 series	QED-95	201323

### 1.2. INTRODUCTION

The QE series is a robust line of high performance and high accuracy pyroelectric joulemeters. Each modular unit is built for durability, compactness and ease of operation. The QE series also offers an exceptionally wide dynamic range and permits energy measurement from UV to far IR.

The QE series are modular low-profile heads, designed for ease of installation in tight optical setups. These detectors have square apertures, providing better compatibility with rectangular beam profiles, such as pulsed gas lasers. A corner mounting thread permits diagonal mounting of the heads to accommodate longer rectangular beams.

The QE series can also be used with QED optional attenuator for improved compatibility with high-energy lasers.

QE series joulemeters require no power source. They can also be used with  $1\text{ M}\Omega$ <sup>1</sup> input impedance oscilloscopes<sup>2</sup> (or fast chart recorders). The calibrated V/J sensitivity is documented in the calibration certificate of each unit. The spectral correction of this sensitivity is also documented in the "Personal wavelength correction™" certificate.

---

<sup>1</sup> The capacitance of the cable linking the joulemeter to the electronic readout and the readout input impedance (capacitance and resistance) constitute the total impedance load seen by the detector. The total load capacitance, excluding the integral cable should be  $\leq 30\text{ pF}$ .

<sup>2</sup> A DB15 to BNC adaptor is required.

### 1.3. PRODUCT NAME STRUCTURE

All products in the QE series are named using the same structure. The table below explains each part of the product name, with the following product as an example: QE25LP-H-MB-QED-INT-D0

Series name	Aperture	Pulse length	Cooling
QE	25	LP	H
Pyroelectric energy detectors	Diameter or width, in mm	LP: Long pulses SP: Short pulses ELP: Extra-long pulses HR: High repetition rate	S: Standalone H: Heatsink B: Cylindrical casing

Absorber	Attenuator	All-in-one meter	Connector type
MB	QED	INT	D0
MB: Standard absorber MT: High repetition rate BL: Organic black	QED: Attenuator (empty): no attenuator	INT: Integra, USB IDR: Integra, RS232 (empty): no meter	D0: Standard (if no meter: DB15)  <i>Custom:</i> C0: BNC, etc.

### 1.4. ABSORBERS

#### 1.4.1. MB: General use, broadband absorber

Our standard absorber offers high damage thresholds and a flat spectral response, making this series of energy detectors a versatile solution that can cover most of your laser energy measurement needs.

#### 1.4.2. MT: Absorber for high repetition rates

Designed for pulsed lasers with high repetition rates, energy detectors with this absorber feature an improved temporal response to accurately measure pulse-to-pulse energy at high repetition rates up to 10 kHz.

#### 1.4.3. QED: Diffusing attenuator for high energy density

Detectors with the QED attenuator are designed for lasers with extreme power and energy density. Thanks to a proprietary absorber that diffuses the measured beam and absorbs it in a larger volume, these detectors have very high damage thresholds.

**NOTE:** This absorber has a high level of back-reflections. Proper laser safety procedures must be used.

QED attenuators can be purchased separately as accessories, or included as part of the product. In this case, this product is calibrated with the QED attenuator in place. You may remove the attenuator, but your measurements will not be calibrated with this configuration.

#### 1.4.4. BL: Low noise, flat spectral response

This absorber is designed for energy measurements with high accuracy at low energy and from the DUV to the FIR.

### 1.4.5. Absorptance curves for all absorbers

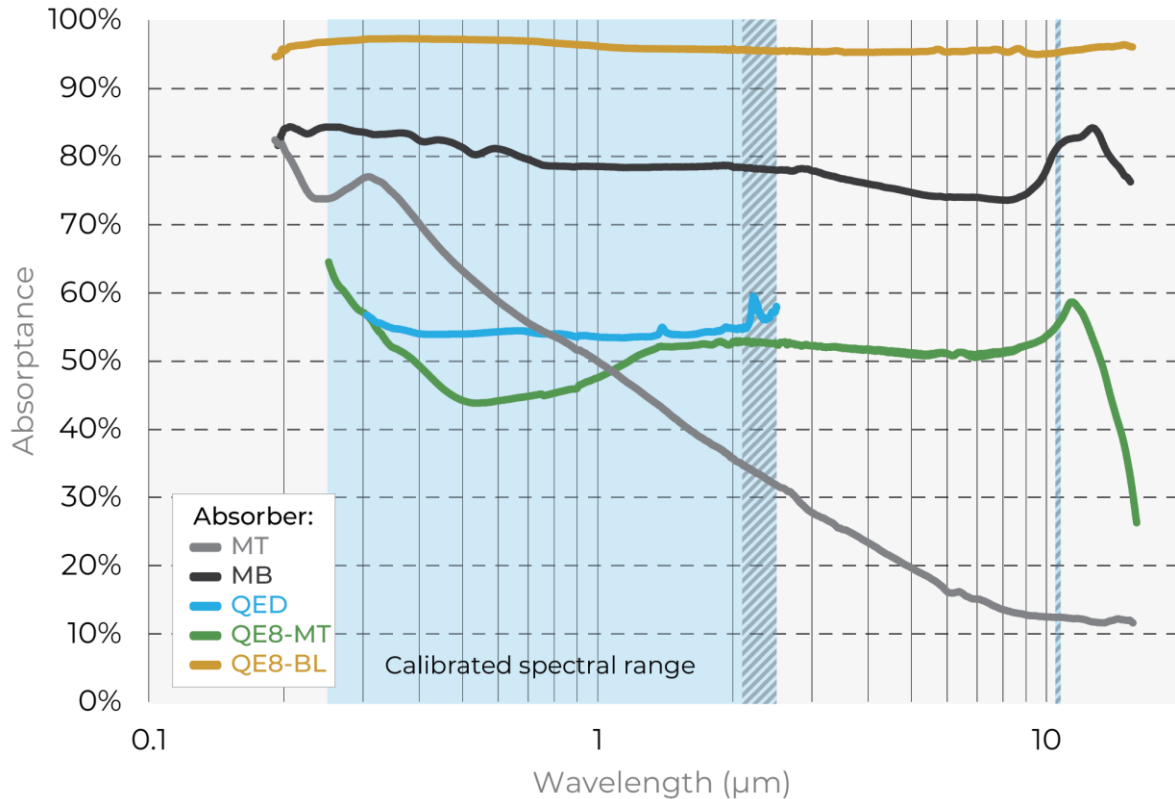

Fig. 1-1 Typical absorption curve for the available absorbers. The calibrated spectral range is indicated in light blue. Extra calibration ranges that can be purchased are indicated by the hatched areas. Note that the QED absorber has a limited spectral range; please refer to the specifications tables for more details.

## 1.5. CONNECTORS AND ALL-IN-ONE METERS

The standard cable length (including the connector) is 2 m, except for the QE12 series, for which it is 1 m.

### 1.5.1. “Smart” DB15 connector

The smart DB15 male connector contains an EEPROM (Electrically Erasable Programmable Read-Only Memory) containing information such as the model of the detector, the calibration sensitivity, and other data relating to the specific QE joulemeter in use.

This connector allows Gentec-EO displays and PC interfaces to adjust their characteristics automatically to the connected power sensor. No calibration procedure is required when installing the power detectors, allowing for fast set-up.

The DB15 connector pin-out is composed of (see Fig. 1-2):

1-	USED BY MONITOR
2-	" " " " "
3-	" " " " "
4-	" " " " "
5-	" " " " "
6-	SIGNAL (+)
7-	"-" SUPPLY VOLTAGE QE8 ONLY
8-	USED BY MONITORS
9-	"+" SUPPLY VOLTAGE QE8 ONLY
10-	USED BY MONITORS
11-	" " " " "
12-	" " " " "
13-	SIGNAL (-)
14-	USED BY MONITOR
15-	" " " " "
SHELL -BODY GROUND	

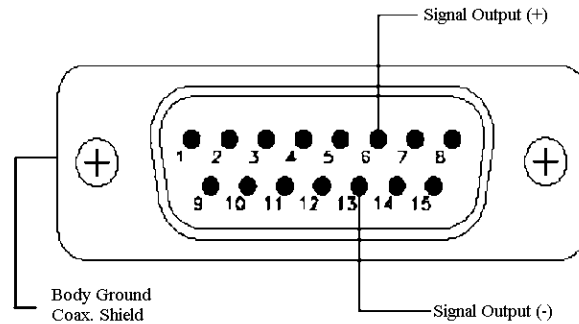

Fig. 1-2 DB15 connector pin-out

**NOTE:** Consult Gentec-EO for supply voltage requirements.

### 1.5.2. **INT: Integra all-in-one meter with USB connector**

Integra USB is an integrated meter that allows you to plug your detector directly into a computer. It communicates via serial commands (see the INTEGRA user manual) and can use our free PC-Gentec-EO software. All specifications are the same as the DB15 version, except for:

- Joulemeter heads have a noise  $\sim 1.3$  x higher.
- Repetition rate is limited to 5200 Hz maximum.

### 1.5.3. **INE: Integra all-in-one meter with USB connector and external trigger**

This Integra USB version includes a BNC connector for an external trigger. See the INTEGRA User Manual for more details.

### 1.5.4. **IDR: Integra all-in-one meter with RS232 connector**

Integra RS232 is an integrated meter that allows you to plug your detector directly into a computer. It communicates via serial commands (see the INTEGRA user manual) and can use our free PC-Gentec-EO software. All specifications are the same as the USB version, except for:

- For repetition rates above 200 Hz, values are sampled.
- Power supply is required. See the INTEGRA user manual for more details.

### 1.5.5. **Custom connectors**

#### C0: BNC connector

The C0 version of the QE series (with BNC connector) does not have the "Smart Interface" function. These joulemeters cannot be used with a Gentec-EO display or PC interface. They must be used with an oscilloscope or an OEM acquisition system.

The BNC connector is quick and easy to install and is the best at shielding EMI noise. This connector allows you to connect the detector directly to an oscilloscope or to a precision microvoltmeter with the correct load impedance.

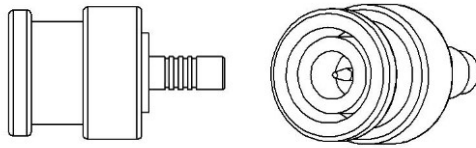

Fig. 1-3 BNC connector

### Other custom connectors

If your application requires another type of connector, contact Gentec-EO for a custom product quote.

## 1.6. SPECIFICATIONS

The following specifications are based on a one-year calibration cycle, an operating temperature of 15 to 28°C and a relative humidity not exceeding 80%. Storage 5 to 45 °C and relative humidity not exceeding 80%.

Condensation must not be present at any time on the detector in operation or storage.

Specifications are subject to change without notice.

	All QE detectors
Recommended load impedance when used with your own measurement instrument	1 MΩ 30 pF

### 1.6.1. Footnotes

Footnotes for the specifications tables are combined here:

- a. Both options will incur additional charges. It is not possible to have both 2.1 μm to 2.5 μm and 10.6 μm calibration added to a single detector. Contact a Gentec-EO representative to learn more about these calibration options or to get a quote.
- b. Assuming max energy density @ 1064 nm, 7 ns laser beam; with a uniform energy distribution; energy applied to full aperture. Increasing the pulse width increases the maximum measurable energy.
- c. At constant power.
- d. With INTEGRA RS-232 ("IDR"), values are sampled for repetition rates above 200 Hz.
- e. Duration at base of pulse. Divide by 2 for FWHM (Full Width at Half Maximum) duration.
- f. Calibrated @ 1.064 μm or 1.070 μm, 10 Hz, semi-Gaussian beam profile, energy applied to 80% of aperture, loaded into 1 MΩ / 30 pF, energy level and pulse width varies according to detector specification.
- g. Excludes non-linearities.
- h. Warning: Detector body can reach 60°C at maximum power.
- i. Maximum measurable energy, maximum energy density and maximum average power can be increased by using an optional QED attenuator.
- j. Detectors with the MT coating can be used within the range 0.19 to 20 μm, however the absorption in the IR wavelengths decreases significantly. This, in turn, reduces the sensitivity and increases the noise level.
- k. A powerful computer processor is required to run PC-M-LINK software at high repetition rates. The repetition rate specification is given using a sufficiently powerful computer. M-LINK can measure up to 6000 Hz pulses using the serial command set.
- l. QE4 is only calibrated at one wavelength. For values other than calibrated wavelength a typical value is recommended but not traceable to NIST.
- m. With QED diffuser, derate these values by 60 % for pulse energies greater than 0.5 J.
- n. Limited by electronics, contact Gentec-EO for different specifications.

**1.6.2. QE12-MB**

	QE12LP-S-MB	QE12LP-H-MB	QE12HR-H-MB	QE12LP-S-MB-QED	QE12LP-H-MB-QED	QE12HR-H-MB-QED
Effective aperture	12 x 12 mm			9 x 9 mm		
Spectral range	0.19 - 20 $\mu\text{m}$			0.266 - 2.1 $\mu\text{m}$		
Calibrated spectral range	0.248 - 2.1 $\mu\text{m}$			0.532 - 2.1 $\mu\text{m}$		
Available extra calibrated ranges <sup>a</sup>	2.1 - 2.5 $\mu\text{m}$			N/A		
Max. pulse energy <sup>b</sup> 1064 nm 266 nm	0.85 J 0.7 J			1.5 J 0.81 J		
Noise equivalent energy (NEE), typical	0.7 $\mu\text{J}$	0.7 $\mu\text{J}$	1.4 $\mu\text{J}$	0.7 $\mu\text{J}$	0.7 $\mu\text{J}$	1.4 $\mu\text{J}$
Max. repetition rate <sup>c,d</sup>	300 Hz	300 Hz	1000 Hz	300 Hz	300 Hz	1000 Hz
Typical rise time (0-100 %)	550 $\mu\text{s}$	550 $\mu\text{s}$	70 $\mu\text{s}$	550 $\mu\text{s}$	550 $\mu\text{s}$	70 $\mu\text{s}$
Max. pulse width, typical <sup>e</sup>	400 $\mu\text{s}$	400 $\mu\text{s}$	40 $\mu\text{s}$	400 $\mu\text{s}$	400 $\mu\text{s}$	40 $\mu\text{s}$
Calibration uncertainty <sup>f,g</sup>	$\pm 3.0\%$ (1064 - 1070 nm) $\pm 4.7\%$ (248 - 299 nm) $\pm 3.7\%$ (300 - 1565 nm) $\pm 4.6\%$ (1566 - 2100 nm)			$\pm 3.0\%$ (1064 - 1070 nm) $\pm 4.5\%$ (532 - 1565 nm) $\pm 5.4\%$ (1566 - 2100 nm)		
Repeatability	< 0.5%					
Max. average power <sup>h</sup>	3 W	5 W	5 W	7.5 W	12.5 W	12.5 W
Max. average power density	10 W/cm <sup>2</sup> @ 3 W	10 W/cm <sup>2</sup> @ 5 W	10 W/cm <sup>2</sup> @ 5 W	600 W/cm <sup>2</sup>		
Pulsed laser damage thresholds <sup>i</sup> 1.064 $\mu\text{m}$ , 7 ns, single-shot 1.064 $\mu\text{m}$ , 7 ns, 10 Hz 532 nm, 7 ns, 10 Hz 266 nm, 7 ns, 10 Hz	-- 600 mJ/cm <sup>2</sup> -- 500 mJ/cm <sup>2</sup>			16 J/cm <sup>2</sup> 8 J/cm <sup>2</sup> 6 J/cm <sup>2</sup> 1 J/cm <sup>2</sup>		
Absorber	MB			QED		
Cooling	Stand-alone	Heatsink	Heatsink	Stand-alone	Heatsink	Heatsink
Dimensions (H x W x D, mm)	36 x 36 x 14	36 x 36 x 33	36 x 36 x 33	41 x 41 x 14	41 x 41 x 38	41 x 41 x 38
Weight (head only)	87 g	117 g	117 g	170 g	200 g	200 g

**1.6.3. QE12-MT**

	QE12SP-S-MT	QE12SP-H-MT	QE12HR-H-MT
Effective aperture	12 x 12 mm		
Spectral range <sup>j</sup>	0.19 - 20 $\mu\text{m}$		
Calibrated spectral range	0.248 - 2.1 $\mu\text{m}$		
Available extra calibrated ranges <sup>a</sup>	2.1 - 2.5 $\mu\text{m}$		
Max. pulse energy <sup>b</sup> 1064 nm 266 nm	0.70 J 0.10 J		
Noise equivalent energy (NEE), typical	0.8 $\mu\text{J}$	0.8 $\mu\text{J}$	1.0 $\mu\text{J}$
Max. repetition rate <sup>c</sup> MAESTRO, U-LINK S-LINK INTEGRA <sup>d</sup> M-LINK <sup>k</sup>	6000 Hz 6000 Hz 5200 Hz 1000 Hz		10 000 Hz
Typical rise time (0-100 %)	20 $\mu\text{s}$	20 $\mu\text{s}$	7 $\mu\text{s}$
Max. pulse width, typical <sup>e</sup>	10 $\mu\text{s}$	10 $\mu\text{s}$	4 $\mu\text{s}$
Calibration uncertainty <sup>f, g</sup>	$\pm 3.0\%$ (1064 – 1070 nm) $\pm 4.7\%$ (248 – 299 nm) $\pm 3.7\%$ (300 – 1565 nm) $\pm 4.6\%$ (1566 – 2100 nm)		
Repeatability	< 0.5%		
Max. average power <sup>h</sup>	3 W	5 W	5 W
Max. average power density	10 W/cm <sup>2</sup> @ 3 W	10 W/cm <sup>2</sup> @ 5 W	10 W/cm <sup>2</sup> @ 5 W
Pulsed laser damage thresholds <sup>i</sup> 1.064 $\mu\text{m}$ , 7 ns, 10 Hz 532 nm, 7 ns, 10 Hz 266 nm, 7 ns, 10 Hz	500 mJ/cm <sup>2</sup> 70 mJ/cm <sup>2</sup> 70 mJ/cm <sup>2</sup>		
Absorber	MT		
Cooling	Stand-alone	Heatsink	Heatsink
Dimensions (H x W x D, mm)	36 x 36 x 14	36 x 36 x 33	36 x 36 x 33
Weight (head only)	87 g	117 g	117 g

**1.6.4. QE25-MB**

	QE25LP-S-MB	QE25LP-H-MB	QE25HR-H-MB	QE25LP-S-MB-QED	QE25LP-H-MB-QED	QE25HR-H-MB-QED
Effective aperture	25 x 25 mm			22 x 22 mm		
Spectral range	0.19 - 20 $\mu\text{m}$			0.266 - 2.1 $\mu\text{m}$		
Calibrated spectral range	0.248 - 2.1 $\mu\text{m}$			0.308 - 2.1 $\mu\text{m}$		
Available extra calibrated ranges <sup>a</sup>	2.1 - 2.5 $\mu\text{m}$ <u>OR</u> 10.6 $\mu\text{m}$			N/A		
Max. pulse energy <sup>b</sup> 1064 nm 266 nm	3.75 J 3.1 J			10 J 4.8 J		
Noise equivalent energy (NEE), typical	4 $\mu\text{J}$	4 $\mu\text{J}$	10 $\mu\text{J}$	4 $\mu\text{J}$	4 $\mu\text{J}$	10 $\mu\text{J}$
Max. repetition rate <sup>c,d</sup>	300 Hz	300 Hz	1000 Hz	300 Hz	300 Hz	1000 Hz
Typical rise time (0-100 %)	550 $\mu\text{s}$	550 $\mu\text{s}$	70 $\mu\text{s}$	550 $\mu\text{s}$	550 $\mu\text{s}$	70 $\mu\text{s}$
Max. pulse width, typical <sup>e</sup>	400 $\mu\text{s}$	400 $\mu\text{s}$	40 $\mu\text{s}$	400 $\mu\text{s}$	400 $\mu\text{s}$	40 $\mu\text{s}$
Calibration uncertainty <sup>f,g</sup>	$\pm 3.0\%$ (1064 - 1070 nm) $\pm 4.7\%$ (248 - 299 nm) $\pm 3.7\%$ (300 - 1565 nm) $\pm 4.6\%$ (1566 - 2100 nm)			$\pm 3.0\%$ (1064 - 1070 nm) $\pm 4.5\%$ (308 - 1565 nm) $\pm 5.4\%$ (1566 - 2100 nm)		
Repeatability	< 0.5%					
Max. average power <sup>h</sup>	5 W	10 W	10 W	15 W	30 W	30 W
Max. average power density	10 W/cm <sup>2</sup> @ 5 W	10 W/cm <sup>2</sup> @ 10 W	10 W/cm <sup>2</sup> @ 10 W	600 W/cm <sup>2</sup>		
Pulsed laser damage thresholds <sup>l,m</sup> 1.064 $\mu\text{m}$ , 7 ns, single-shot 1.064 $\mu\text{m}$ , 7 ns, 10 Hz 532 nm, 7 ns, 10 Hz 266 nm, 7 ns, 10 Hz	-- 600 mJ/cm <sup>2</sup> -- 500 mJ/cm <sup>2</sup>			16 J/cm <sup>2</sup> 8 J/cm <sup>2</sup> 6 J/cm <sup>2</sup> 1 J/cm <sup>2</sup>		
Absorber	MB			QED		
Cooling	Stand-alone	Heatsink	Heatsink	Stand-alone	Heatsink	Heatsink
Dimensions (H x W x D, mm)	50 x 50 x 14	50 x 50 x 52.7	50 x 50 x 52.7	55 x 55 x 19	55 x 55 x 57.7	55 x 55 x 57.7
Weight (head only)	120 g	187 g	187 g	200 g	267 g	267 g

**1.6.5. QE25-MT**

	QE25SP-S-MT	QE25SP-H-MT	QE25HR-H-MT
Effective aperture	25 x 25 mm		
Spectral range <sup>j</sup>	0.19 - 20 $\mu\text{m}$		
Calibrated spectral range	0.248 - 2.1 $\mu\text{m}$		
Available extra calibrated ranges <sup>a</sup>	2.1 - 2.5 $\mu\text{m}$		
Max. pulse energy <sup>b</sup> 1064 nm 266 nm	3.0 J 0.44 J		
Noise equivalent energy (NEE), typical	2 $\mu\text{J}$	2 $\mu\text{J}$	3 $\mu\text{J}$
Max. repetition rate <sup>c</sup> MAESTRO, U-LINK S-LINK INTEGRA <sup>d</sup> M-LINK <sup>k</sup>	6000 Hz 6000 Hz 5200 Hz 1000 Hz		10 000 Hz
Typical rise time (0-100 %)	20 $\mu\text{s}$	20 $\mu\text{s}$	7 $\mu\text{s}$
Max. pulse width, typical <sup>e</sup>	10 $\mu\text{s}$	10 $\mu\text{s}$	4 $\mu\text{s}$
Calibration uncertainty <sup>f, g</sup>	$\pm 3.0\%$ (1064 – 1070 nm) $\pm 4.7\%$ (248 – 299 nm) $\pm 3.7\%$ (300 – 1565 nm) $\pm 4.6\%$ (1566 – 2100 nm)		
Repeatability	< 0.5%		
Max. average power <sup>h</sup>	5 W	10 W	10 W
Max. average power density	10 W/cm <sup>2</sup> @ 5 W	10 W/cm <sup>2</sup> @ 10 W	10 W/cm <sup>2</sup> @ 10 W
Pulsed laser damage thresholds <sup>i</sup> 1.064 $\mu\text{m}$ , 7 ns, 10 Hz 532 nm, 7 ns, 10 Hz 266 nm, 7 ns, 10 Hz	500 mJ/cm <sup>2</sup> 70 mJ/cm <sup>2</sup> 70 mJ/cm <sup>2</sup>		
Absorber	MT		
Cooling	Stand-alone	Heatsink	Heatsink
Dimensions (H x W x D, mm)	50 x 50 x 14	50 x 50 x 52.7	50 x 50 x 52.7
Weight (head only)	120 g	187 g	187 g

**1.6.6. QE50-MB**

	QE50LP-S-MB	QE50LP-H-MB	QE50LP-S-MB-QED	QE50LP-H-MB-QED
Effective aperture	50 x 50 mm		47 x 47 mm	
Spectral range	0.19 - 20 $\mu\text{m}$		0.266 – 2.1 $\mu\text{m}$	
Calibrated spectral range	0.248 - 2.1 $\mu\text{m}$		0.308 - 2.1 $\mu\text{m}$	
Available extra calibrated ranges <sup>a</sup>	2.1 - 2.5 $\mu\text{m}$ <u>QR</u> 10.6 $\mu\text{m}$		N/A	
Max. pulse energy <sup>b</sup> 1064 nm 266 nm	15 J 12.5 J		40 J 22 J	
Noise equivalent energy (NEE), typical	10 $\mu\text{J}$			
Max. repetition rate <sup>c</sup>	200 Hz			
Typical rise time (0-100 %)	900 $\mu\text{s}$			
Max. pulse width, typical <sup>e</sup>	675 $\mu\text{s}$			
Calibration uncertainty <sup>f, g</sup>	$\pm 3.0\%$ (1064 – 1070 nm) $\pm 4.7\%$ (248 – 299 nm) $\pm 3.7\%$ (300 – 1565 nm) $\pm 4.6\%$ (1566 – 2100 nm)		$\pm 3.0\%$ (1064 – 1070 nm) $\pm 4.5\%$ (308 – 1565 nm) $\pm 5.4\%$ (1566 – 2100 nm)	
Repeatability	< 0.5%			
Max. average power <sup>h</sup>	10 W	20 W	25 W	45 W
Max. average power density	10 W/cm <sup>2</sup> @ 10 W	5 W/cm <sup>2</sup> @ 20 W	600 W/cm <sup>2</sup>	
Pulsed laser damage thresholds <sup>l, m</sup> 1.064 $\mu\text{m}$ , 7 ns, single-shot 1.064 $\mu\text{m}$ , 7 ns, 10 Hz 532 nm, 7 ns, 10 Hz 266 nm, 7 ns, 10 Hz	-- 600 mJ/cm <sup>2</sup> -- 500 mJ/cm <sup>2</sup>		16 J/cm <sup>2</sup> 8 J/cm <sup>2</sup> 6 J/cm <sup>2</sup> 1 J/cm <sup>2</sup>	
Absorber	MB		QED	
Cooling	Stand-alone	Heatsink	Stand-alone	Heatsink
Dimensions (H x W x D, mm)	75 x 75 x 15	75 x 75 x 44	80 x 80 x 20	80 x 80 x 49
Weight (head only)	209 g	338 g	336 g	465 g

**1.6.7. QE50-MT**

	QE50SP-S-MT	QE50SP-H-MT
Effective aperture	50 x 50 mm	
Spectral range	0.19 - 20 $\mu\text{m}$	
Calibrated spectral range	0.248 - 2.1 $\mu\text{m}$	
Available extra calibrated ranges <sup>a</sup>	2.1 - 2.5 $\mu\text{m}$	
Max. pulse energy <sup>b</sup>		
1064 nm	13 J	
266 nm	1.8 J	
Noise equivalent energy (NEE), typical	10 $\mu\text{J}$	
Max. repetition rate <sup>c,d</sup>	4000 Hz	
Typical rise time (0-100 %)	20 $\mu\text{s}$	
Max. pulse width, typical <sup>e</sup>	10 $\mu\text{s}$	
Calibration uncertainty <sup>f,g</sup>	$\pm 3.0\%$ (1064 – 1070 nm) $\pm 4.7\%$ (248 – 299 nm) $\pm 3.7\%$ (300 – 1565 nm) $\pm 4.6\%$ (1566 – 2100 nm)	
Repeatability	< 0.5%	
Max. average power <sup>h</sup>	10 W	20 W
Max. average power density	10 W/cm <sup>2</sup> @ 10 W	5 W/cm <sup>2</sup> @ 20 W
Pulsed laser damage thresholds <sup>i</sup>		
1.064 $\mu\text{m}$ , 7 ns, 10 Hz	500 mJ/cm <sup>2</sup>	
532 nm, 7 ns, 10 Hz	70 mJ/cm <sup>2</sup>	
266 nm, 7 ns, 10 Hz	70 mJ/cm <sup>2</sup>	
Absorber	MT	
Cooling	Stand-alone	Heatsink
Dimensions (H x W x D, mm)	75 x 75 x 15	75 x 75 x 44
Weight (head only)	209 g	338 g

**1.6.8. QE65-MB**

	QE65LP-S-MB	QE65LP-H-MB	QE65ELP-S-MB	QE65ELP-H-MB	QE65LP-S-MB-QED	QE65LP-H-MB-QED
Effective aperture	65 x 65 mm				62 x 62 mm	
Spectral range	0.19 - 20 $\mu\text{m}$				0.266 - 2.1 $\mu\text{m}$	
Calibrated spectral range	0.248 - 2.1 $\mu\text{m}$				0.308 - 2.1 $\mu\text{m}$	
Available extra calibrated ranges <sup>a</sup>	2.1 - 2.5 $\mu\text{m}$ <u>OR</u> 10.6 $\mu\text{m}$				N/A	
Max. pulse energy <sup>b</sup> 1064 nm 266 nm	25 J 20 J		50 J ( $\mu\text{s}$ pulse, single-shot)		50 J 35 J	
Noise equivalent energy (NEE), typical	10 $\mu\text{J}$		20 $\mu\text{J}$		10 $\mu\text{J}$	
Max. repetition rate <sup>c</sup>	100 Hz		20 Hz		100 Hz	
Typical rise time (0-100 %)	1000 $\mu\text{s}$		6000 $\mu\text{s}$		1000 $\mu\text{s}$	
Max. pulse width, typical <sup>e</sup>	700 $\mu\text{s}$		5000 $\mu\text{s}$		700 $\mu\text{s}$	
Calibration uncertainty <sup>f,g</sup>	$\pm 3.0\%$ (1064 - 1070 nm) $\pm 4.7\%$ (248 - 299 nm) $\pm 3.7\%$ (300 - 1565 nm) $\pm 4.6\%$ (1566 - 2100 nm)		$\pm 4.0\%$ (1064 - 1070 nm) $\pm 5.7\%$ (248 - 299 nm) $\pm 4.7\%$ (300 - 1565 nm) $\pm 5.6\%$ (1566 - 2100 nm)		$\pm 3.0\%$ (1064 - 1070 nm) $\pm 4.5\%$ (308 - 1565 nm) $\pm 5.4\%$ (1566 - 2100 nm)	
Repeatability	< 0.5%					
Max. average power <sup>h</sup>	12 W	40 W	12 W	40 W	30 W	90 W
Max. average power density	10 W/cm <sup>2</sup> @ 12 W	5 W/cm <sup>2</sup> @ 40 W	10 W/cm <sup>2</sup> @ 12 W	5 W/cm <sup>2</sup> @ 40 W	600 W/cm <sup>2</sup>	
Pulsed laser damage thresholds <sup>l,m</sup> 1.064 $\mu\text{m}$ , 150 $\mu\text{s}$ , 10 Hz 1.064 $\mu\text{m}$ , 7 ns, single-shot 1.064 $\mu\text{m}$ , 7 ns, 10 Hz 532 nm, 7 ns, 10 Hz 266 nm, 7 ns, 10 Hz	1200 mJ/cm <sup>2</sup> -- 600 mJ/cm <sup>2</sup> -- 500 mJ/cm <sup>2</sup>				14 J/cm <sup>2</sup> 16 J/cm <sup>2</sup> 8 J/cm <sup>2</sup> 6 J/cm <sup>2</sup> 1 J/cm <sup>2</sup>	
Absorber	MB				QED	
Cooling	Stand-alone	Heatsink	Stand-alone	Heatsink	Stand-alone	Heatsink
Dimensions (H x W x D, mm)	92 x 92 x 20	92 x 92 x 99	92 x 92 x 20	92 x 92 x 99	97 x 97 x 25	97 x 97 x 105
Weight (head only)	440 g	900 g	440 g	900 g	640 g	1100 g

**1.6.9. QE95-MB**

	QE95LP-S-MB	QE95LP-H-MB	QE95ELP-S-MB	QE95ELP-H-MB	QE95LP-S-MB-QED	QE95LP-H-MB-QED
Effective aperture	95 mm Ø				90 mm Ø	
Spectral range	0.19 - 20 µm				0.266 – 2.1 µm	
Calibrated spectral range	0.248 - 2.1 µm				0.308 - 2.1 µm	
Available extra calibrated ranges <sup>a</sup>	2.1 - 2.5 µm <u>OR</u> 10.6 µm				N/A	
Max. pulse energy <sup>b</sup> 1064 nm 266 nm	35 J 30 J		70 J (µs pulse, single-shot)		60 J 50 J	
Noise equivalent energy (NEE), typical	15 µJ		30 µJ		15 µJ	
Max. repetition rate <sup>c</sup>	40 Hz		10 Hz		40 Hz	
Typical rise time (0-100 %)	2000 µs		6000 µs		2000 µs	
Max. pulse width, typical <sup>e</sup>	1500 µs		5000 µs		1500 µs	
Calibration uncertainty <sup>f,g</sup>	± 3.0 % (1064 – 1070 nm) ± 4.7 % (248 – 299 nm) ± 3.7 % (300 – 1565 nm) ± 4.6 % (1566 – 2100 nm)		± 4.0 % (1064 – 1070 nm) ± 5.7 % (248 – 299 nm) ± 4.7 % (300 – 1565 nm) ± 5.6 % (1566 – 2100 nm)		± 3.0 % (1064 – 1070 nm) ± 4.5 % (308 – 1565 nm) ± 5.4 % (1566 – 2100 nm)	
Repeatability	< 0.5%					
Max. average power <sup>h</sup>	20 W	40 W	20 W	40 W	45 W	90 W
Max. average power density	10 W/cm <sup>2</sup> @ 12 W	5 W/cm <sup>2</sup> @ 40 W	10 W/cm <sup>2</sup> @ 12 W	5 W/cm <sup>2</sup> @ 40 W	600 W/cm <sup>2</sup>	
Pulsed laser damage thresholds <sup>l,m</sup> 1.064 µm, 150 µs, 10 Hz 1.064 µm, 7 ns, single-shot 1.064 µm, 7 ns, 10 Hz 532 nm, 7 ns, 10 Hz 266 nm, 7 ns, 10 Hz	1200 mJ/cm <sup>2</sup> -- 600 mJ/cm <sup>2</sup> -- 500 mJ/cm <sup>2</sup>				14 J/cm <sup>2</sup> 16 J/cm <sup>2</sup> 8 J/cm <sup>2</sup> 6 J/cm <sup>2</sup> 1 J/cm <sup>2</sup>	
Absorber	MB				QED	
Cooling	Stand-alone	Heatsink	Stand-alone	Heatsink	Stand-alone	Heatsink
Dimensions (H x W x D, mm)	122 x 122 x 20	122 x 122 x 99	122 x 122 x 20	122 x 122 x 99	127 x 127 x 25	127 x 127 x 104
Weight (head only)	0.78 kg	1.2 kg	0.78 kg	1.2 kg	1.1 kg	1.55 kg

**1.6.10. QE195-MB**

	QE195LP-S-MB	QE195LP-H-MB
Effective aperture	195 mm Ø	
Spectral range	0.19 - 20 µm	
Calibrated spectral range	0.248 - 2.1 µm	
Available extra calibrated ranges <sup>a</sup>	2.1 – 2.5 µm OR 10.6 µm (Contact us)	
Max. pulse energy <sup>b,n</sup> 1064 nm	125 J	
Noise equivalent energy (NEE), typical	0.5 mJ	
Max. repetition rate <sup>c</sup>	40 Hz	
Typical rise time (0-100 %)	1500 µs	
Max. pulse width, typical <sup>e</sup>	1000 µs	
Calibration uncertainty <sup>f,g</sup>	± 3.0 % (1064 – 1070 nm) ± 4.7 % (248 – 299 nm) ± 3.7 % (300 – 1565 nm) ± 4.6 % (1566 – 2100 nm)	
Repeatability	< 0.5%	
Max. average power <sup>h</sup>	80 W	160 W
Max. average power density	10 W/cm <sup>2</sup> @ 12 W 5 W/cm <sup>2</sup> @ 40 W	10 W/cm <sup>2</sup> @ 12 W 5 W/cm <sup>2</sup> @ 40 W 2.4 W/cm <sup>2</sup> @ 160 W
Pulsed laser damage thresholds <sup>l,m</sup> 1.064 µm, 150 µs, 10 Hz 1.064 µm, 7 ns, 10 Hz 266 nm, 7 ns, 10 Hz	1200 mJ/cm <sup>2</sup> 600 mJ/cm <sup>2</sup> 500 mJ/cm <sup>2</sup>	
Absorber	MB	
Cooling	Stand-alone	Heatsink
Dimensions (H x W x D, mm)	229 x 229 x 23.5 mm	229 x 229 x 103 mm
Weight (head only)	3.1 kg	4.9 kg

**1.6.11. QE8-B**

	QE8SP-B-MT	QE8SP-B-BL
Effective aperture	7.8 x 7.8 mm	
Spectral range	0.19 - 20 $\mu\text{m}$	
Calibrated spectral range	0.248 - 2.1 $\mu\text{m}$	
Available extra calibrated ranges <sup>a</sup>	2.1 - 2.5 $\mu\text{m}$	
Max. pulse energy at 1064 nm <sup>b</sup> MAESTRO, U-LINK S-LINK M-LINK	0.93 mJ 1.1 mJ 1.3 mJ	2.5 mJ 2.9 mJ 3.6 mJ
Noise equivalent energy (NEE), typical MAESTRO, U-LINK S-LINK, M-LINK	80 nJ 50 nJ	150 nJ 100 nJ
Max. repetition rate <sup>c, d</sup>	1000 Hz	400 Hz
Typical rise time (0-100 %)	30 $\mu\text{s}$	
Max. pulse width, typical <sup>e</sup>	10 $\mu\text{s}$	
Calibration uncertainty <sup>f, g</sup>	$\pm 4.0\%$ (1064 – 1070 nm) $\pm 5.7\%$ (248 – 299 nm) $\pm 4.7\%$ (300 – 1565 nm) $\pm 5.6\%$ (1566 – 2100 nm)	
Repeatability	< 0.5%	
Max. average power <sup>h</sup>	0.5 W	
Max. average power density	1 W/cm <sup>2</sup>	
Pulsed laser damage thresholds <sup>i</sup> 1.064 $\mu\text{m}$ , 7 ns, 10 Hz	50 mJ/cm <sup>2</sup>	
Absorber	MT	BL
Cooling	Stand-alone	
Dimensions ( $\varnothing$ x D, mm)	38.1 $\varnothing$ x 27.4	
Weight (head only)	91 g	

**1.6.12. QE4-MT**

	QE4SP-S-MT
Effective aperture	3.7 mm Ø
Spectral range	0.19 - 20 µm
Calibrated spectral range <sup>l</sup>	1.064 µm
Max. pulse energy <sup>b</sup> 1064 nm 266 nm	43 mJ 7.6 mJ
Noise equivalent energy (NEE), typical	1 µJ
Max. repetition rate <sup>c</sup> MAESTRO, U-LINK, S-LINK INTEGRA <sup>d</sup> M-LINK <sup>k</sup>	6000 Hz 5200 Hz 1000 Hz
Typical rise time (0-100 %)	20 µs
Max. pulse width, typical <sup>e</sup>	10 µs
Calibration uncertainty <sup>f, g, l</sup>	± 4.0 % (1064 nm only)
Repeatability	< 0.5%
Max. average power <sup>h</sup>	0.3 W
Max. average power density	1 W/cm <sup>2</sup>
Pulsed laser damage thresholds <sup>i</sup> 1.064 µm, 7 ns, 10 Hz 0.266 µm, 7 ns, 10 Hz	400 mJ/cm <sup>2</sup> 70 mJ/cm <sup>2</sup>
Absorber	MT
Connector	BNC BNC to DB15 adaptor cable included
Cooling	Stand-alone
Dimensions (H x W x D, mm)	20 x 17.5 x 30
Weight (head only)	20 g

### 1.6.13. QED attenuators

The QED attenuators increase the energy, energy density, average power and average power density capabilities of the QE series.

They are engineered to typically transmit 30-50% of the incident radiation to the detector in a near Lambertian pattern (very wide diffusion pattern).

They feature ease of installation and removal.

The QED attenuators can be optionally calibrated when purchased at the same time as a corresponding QE joulemeter.

	QED12	QED25	QED50	QED65	QED95	QED195
Spectral range	0.266 to 2.5 $\mu\text{m}$					
Available extra calibrated ranges (for QE with MB absorber)	0.532 to 2.1 $\mu\text{m}$	0.308 to 2.1 $\mu\text{m}$				N/A
Available extra calibrated ranges (for QE with MT absorber)	Either 532 nm or 1064 nm	0.308 to 2.1 $\mu\text{m}$		N/A		
Typical reflectance	40 - 50%					
Max. energy density <sup>m</sup> 1064 nm, 7 ns, Single shot 1064 nm, 7 ns, 10 Hz 532 nm, 7 ns, 10 Hz 266 nm, 7 ns, 10 Hz	16 J/cm <sup>2</sup> 8 J/cm <sup>2</sup> 6 J/cm <sup>2</sup> 1 J/cm <sup>2</sup>				- 8 J/cm <sup>2</sup> 6 J/cm <sup>2</sup> 1 J/cm <sup>2</sup>	
Dimensions (H x W x D, mm)	30.5 x 41 x 12.5	44 x 55 x 12.5	69 x 80 x 12.5	85 x 97 x 12.5	115 x 127 x 12.5	223 x 237 x 13.8
For use with	QE12	QE25	QE50	QE65	QE95	QE195

Depending on how you plan to use a QE detector and QED attenuator, different purchasing and calibration options are available.

	QE name contains "-QED"	QE name does not contain "-QED"		
Example	QE25LP-S-MB-QED-D0	QE25LP-S-MB-D0 and QED25		
Extra calibration	None	QED-CAL-1	QED-CAL-3	None
Calibrated spectral range when used with QED in place	Fully calibrated	Calibrated at one wavelength	Fully calibrated when using the DB15 adaptor	Not calibrated
Calibrated spectral range when used without QED	Not calibrated	Fully calibrated	Fully calibrated	Fully calibrated

## 2. OPERATING INSTRUCTIONS

### 2.1. SAFETY

#### WARNINGS:

- Be careful not to exceed the maximum levels and densities of, energy, peak power and average power, stated in the specifications. The use of a damage test target is strongly recommended.
- At maximum average power, QE series joulemeter bodies can reach 60°C and can represent a burn hazard if handled with bare hands.
- A diffuse back reflection of ~ 30% is present from the joulemeter's optical absorber.

**NOTE:** As with all large aperture pyroelectric devices, these detectors have some position and beam size sensitivity. For the most accurate measurements, the beam should normally be centered on the sensor surface and the beam diameter should ideally be close to that of the original calibration conditions, which is 100% encircled energy (of a semi-Gaussian beam stopped at  $1/e^2$ ) applied to a diameter equal to 80% of the detector aperture. The use of a QED attenuator, a divergent lens, a Lambertian diffuser such as opal glass, or any other method of beam spreading, is recommended for this purpose. Please take note that all of the laser light must be directed within the detector aperture and that the transmission loss through the optical component must be known.

### 2.2. WHEN USED WITH A COMPATIBLE MONITOR

Refer to the respective monitor's instruction manual for further information.

#### 2.2.1. General instructions

- 1- Install the joulemeter on its optical stand.
- 2- Connect the joulemeter to the Gentec-EO laser energy monitor (see Fig. 2-1).

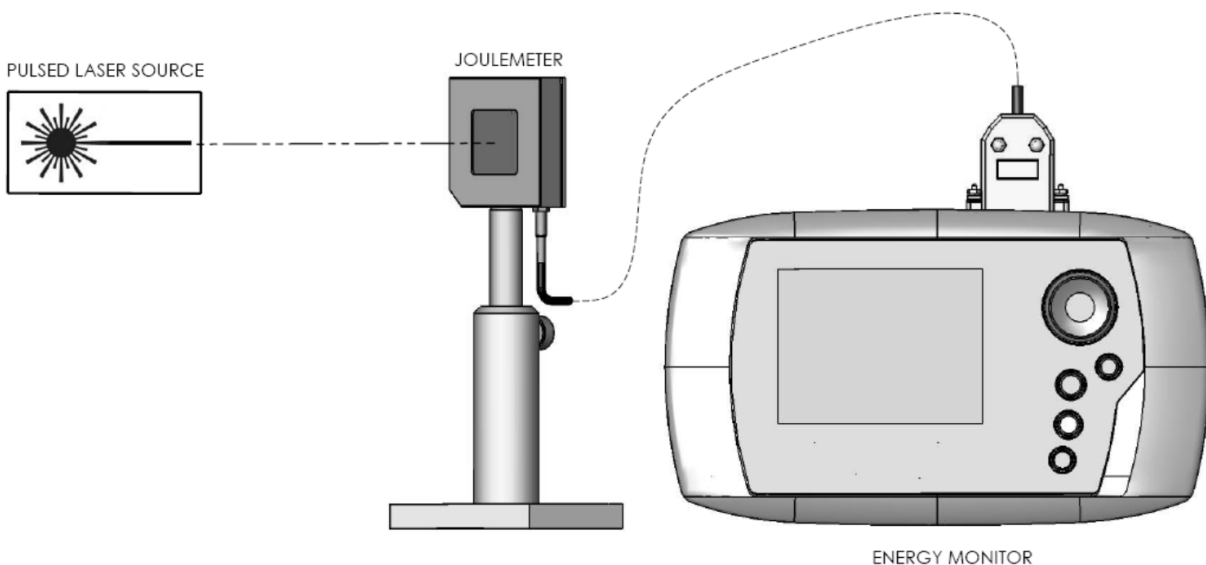

Fig. 2-1 Measurement setup

**NOTE:** The parameters programmed in the DB15 "Smart Interface" are for a 1 M $\Omega$  / 30 pF load impedance.

- 3- Remove the detector's protective cover, when applicable.
- 4- Place the joulemeter head into the laser beam path (laser beam must be contained within the aperture).

### 2.2.2. Working at wavelengths other than 1.064µm (except with QED attenuator)

The monitor will automatically configure itself using the data stored in the EEPROM of the DB15 "Smart Interface". This includes the calibration sensitivity and wavelength corrections for 20 current wavelengths.

For more precise measurements with a QE series joulemeter at wavelengths other than those already corrected by the "Personal wavelength correction™" data programmed into the "Smart Interface", a correction factor must be set in the monitor to compensate for the change in sensitivity of the joulemeter caused by the change in absorption of the optical absorber at different wavelengths.

To correct for the change in absorption refer to the spectral curve of the "Personal wavelength correction™" certificate supplied for the joulemeter and calculate K by taking the percentage difference between the absorption @1.064µm and that at the desired wavelength.

$$K = \frac{A(\lambda_1)}{A(@1.064\mu m)}$$

Here  $A(\lambda_1)$  = Absorption of the QE @ the desired wavelength.

$A(@1.064\mu m)$  = Absorption of the QE @ 1.064µm

A sample calculation follows:

$$A(\lambda_1) = 92 \%$$

$$A(@1.064\mu m) = 94 \%$$

$$K = \frac{A(\lambda_1)}{A(@1.064\mu m)} \times 100$$

$$K = \frac{92\%}{94\%} \times 100 = 0.9787 \times 100 = 97.87 \%$$

and is the Correction Factor to be set in the monitor.

## 2.3. USING AN OSCILLOSCOPE

### 2.3.1. General instructions

- 1- Install tall the joulemeter on its optical stand
- 2- Connect the joulemeter to the oscilloscope.

**NOTE:** The required load impedance is 1 MΩ / 30 pF.

An optional DB15 to BNC adaptor may be required when used in conjunction with an oscilloscope.

- 3- Remove the detector's protective cover, when applicable.
- 4- Place the joulemeter head into the laser beam path (laser beam must be contained within the aperture).
- 5- Adjust the oscilloscope to trigger on the joulemeter pulse or on the laser sync. signal.
- 6- Measure the foot-to-crest peak voltage generated by the joulemeter.
- 7- Determine the joulemeter Volt/Joule sensitivity from the detector identification label or calibration certificate. Choose the value stated for the wavelength being used.
- 8- Calculate the optical energy using the following equation:

$$\text{Energy} = V_{\text{peak}} / \text{Calibration sensitivity}$$

Ex:

$$V_{\text{peak}} = 1 \text{ V}$$

Detector calibration sensitivity = 10 V/J

Energy = 1 V / 10 V/J = 100 mJ

**NOTE:** Exclude any DC offset from the pulse peak value measurement; this offset is a function of the repetition rate.

### 2.3.2. Working at other wavelengths than 1.064µm

For measurements with a QE series joulemeter at wavelengths other than 1.064 µm, a correction factor must be set to compensate for the change in sensitivity of the joulemeter caused by the change in absorption of the optical absorber at different wavelengths.

To correct for the change in absorption refer to the spectral curve of the "Personal wavelength correction™" certificate supplied for the joulemeter and calculate K by taking the percentage difference between the absorption @1.064 µm and that at the desired wavelength.

$$K = \frac{A(\lambda_1)}{A(@1.064\mu m)}$$

Energy =  $V_{\text{peak}}$  / Calibration sensitivity / K

Here  $A(\lambda_1)$  = Absorption of the QE @ the desired wavelength.

$A(@1.064\mu m)$  = Absorption of the QE @ 1.064µm

A sample calculation follows:

$$A(\lambda_1) = 92 \%$$

$$A(@1.064\mu m) = 94 \%$$

$$K = \frac{A(\lambda_1)}{A(@1.064\mu m)} \times 100$$

$$K = \frac{92\%}{94\%} \times 100 = 0.9787 \times 100 = 97.87 \%$$

Ex:

$$V_{\text{peak}} = 1 \text{ V}$$

Detector calibration sensitivity @1.064µm = 10 V/J

Energy = 1 V / 10 V/J / 97.87% = 102.18 mJ

### 3. DAMAGE TO THE OPTICAL ABSORBER MATERIALS

At any time, the beam's incident area should not be less than 10% of the detector's aperture. Please contact Gentec-EO to make measurements with such smaller beams.

Damage is usually caused by exceeding the manufacturer's specified maximum incident:

- Average power density
- Peak pulse power density
- Single pulse energy density

Refer to the QE series joulemeter specifications pages. This damage can also be caused when using a detector with a contaminated absorber or attenuator surface.

The quoted damage thresholds in the specifications section refer to a visible alteration of the absorber aperture. The use of the appropriate "QE series Test Target " is suggested in order to ensure that the laser beam will not damage the detector's absorber. In practice, a slight alteration will not affect the joulemeter response. Consider the joulemeter to be damaged and/or out of calibration when large-scale damage is evident or you can see the metal electrode beneath the absorber. In case of visible damage to the absorber, contact Gentec-EO for evaluation, repair, recalibration, or replacement.

For a QED attenuator mounted on a QE series joulemeter, consider the detector to be damaged and/or out of calibration:

- In the presence of an optically eroded front optical component or in the presence of sparking at the front component, accompanied by a sharp snapping noise: this phenomenon is related to high single pulse energy density and high peak pulse power density.
- In the presence of shattered or molten optical components: this phenomenon is related to high average power density.
- In the presence of a damaged absorber.

**In the case of a TEM<sub>00</sub> (Gaussian) beam, the maximum peak power and energy density can be calculated using the following equation:**

$$\text{Density (power or energy)} \approx \frac{2I_0}{\pi w^2}$$

Where  $I_0$  is the total beam power or energy

$w$  is the beam radius at  $1/e^2$

$$\pi = 3.1416$$

**NOTE:** The beam waist for a TEM<sub>00</sub> beam is the radius of a circle centered on the beam axis and containing 86 % of the beam energy. Ref.: SIEGMAN, A.E., An Introduction to Lasers and Masers, p. 313 (McGraw-Hill series in the Fundamentals of Electronic Science).

Example of energy density calculation;

$$I_0 = 1 \text{ J (total energy)}$$

$$w = 1 \text{ cm}$$

$$\text{Energy density} = \frac{2 \times 1 \text{ J}}{\pi \times 1 \text{ cm}^2} = 0.64 \text{ J/cm}^2$$

## 4. DECLARATION OF CONFORMITY



Application of Council Directive(s): 2014/30/EU EMC Directive

Manufacturer's Name: Gentec Electro Optics, Inc.  
 Manufacturer's Address: 445 St-Jean Baptiste, suite 160  
 (Québec), Canada G2E 5N7

European Representative's Name: Laser Component S.A.S  
 Representative's Address: 45 bis Route des Gardes  
 92190 Meudon (France)

Type of Equipment: Laser Energy Meter  
 Model No.: QE series  
 Year of test & manufacture: 2016

Standard(s) to which Conformity is declared: EN 61326-1: 2006 Emission generic standard

Standard	Description	Performance Criteria
CISPR 11 :2009 A1 :2010	Industrial, scientific and medical equipment – Radio-frequency disturbance characteristics – Limits and methods of measurement	Class A
EN 61000-4-2 2009	Electromagnetic compatibility (EMC) – Part 4-2: Testing and measurement techniques- Electrostatic discharge.	Class B
EN61000-4-3 2006+A2:2010	Electromagnetic compatibility (EMC) – Part 4-3: Testing and measurement techniques- Radiated, Radio Frequency, electromagnetic field immunity test.	Class A
EN61000-4-4 2012	Electromagnetic compatibility (EMC) – Part 4-4: Testing and measurement techniques- Electrical fast transient/burst immunity test.	Class B
EN 61000-4-5 2006	Electromagnetic compatibility (EMC) – Part 4-5: Testing and measurement techniques- Surge immunity test.	Class B
EN 61000-4-6 2013	Electromagnetic compatibility (EMC) – Part 4-6: Testing and measurements techniques- Immunity to conducted Radio Frequency.	Class A
EN 61000-4-11 2004	Electromagnetic compatibility (EMC) – Part 4-11: Testing and measurement techniques- Voltage dips, short interruptions and voltage variations immunity tests. Voltage dips: 0% during 1 cycle 40% during 10 cycles 70% during 25 cycles Short interruptions: 0% during 250 cycles	Class B Class B Class C Class C
EN 61000-3-2:2006 +A1:2009	Electromagnetic compatibility (EMC) - Part 3-2: Limits - Limits for harmonic current emissions (equipment input current <= 16 A per phase)	Class A

I, the undersigned, hereby declare that the equipment specified above conforms to the above Directive(s) and Standard(s)

Place: Quebec (Quebec)  
 Date : July 15 2016

(President)

## 5. UKCA DECLARATION OF CONFORMITY

Application of Council Directive(s): 2014/30/EU EMC Directive



Manufacturer's Name: Gentec Electro Optics, Inc.  
 Manufacturer's Address: 445 St-Jean Baptiste, suite 160  
 (Québec), Canada G2E 5N7

European representative's Name: Laser Component S.A.S  
 Representative's Address: 45 bis Route des Gardes  
 92190 Meudon (France)

Type of Equipment: Laser Energy Meter  
 Model No.: QE series  
 Year of test & manufacture: 2016

Standard(s) to which Conformity is declared: EN 61326-1: 2006 Emission generic standard

Standard	Description	Performance Criteria
CISPR 11 :2009 A1 :2010	Industrial, scientific and medical equipment – Radio-frequency disturbance characteristics – Limits and methods of measurement	Class A
EN 61000-4-2 2009	Electromagnetic compatibility (EMC) – Part 4-2: Testing and measurement techniques- Electrostatic discharge.	Class B
EN61000-4-3 2006+A2:2010	Electromagnetic compatibility (EMC) – Part 4-3: Testing and measurement techniques- Radiated, Radio Frequency, electromagnetic field immunity test.	Class A
EN61000-4-4 2012	Electromagnetic compatibility (EMC) – Part 4-4: Testing and measurement techniques- Electrical fast transient/burst immunity test.	Class B
EN 61000-4-5 2006	Electromagnetic compatibility (EMC) – Part 4-5: Testing and measurement techniques- Surge immunity test.	Class B
EN 61000-4-6 2013	Electromagnetic compatibility (EMC) – Part 4-6: Testing and measurements techniques- Immunity to conducted Radio Frequency.	Class A
EN 61000-4-11 2004	Electromagnetic compatibility (EMC) – Part 4-11: Testing and measurement techniques- Voltage dips, short interruptions and voltage variations immunity tests. Voltage dips: 0% during 1 cycle 40% during 10 cycles 70% during 25 cycles Short interruptions: 0% during 250 cycles	Class B Class B Class C Class C
EN 61000-3-2:2006 +A1:2009	Electromagnetic compatibility (EMC) - Part 3-2: Limits - Limits for harmonic current emissions (equipment input current <= 16 A per phase)	Class A

I, the undersigned, hereby declare that the equipment specified above conforms to the above Directive(s) and Standard(s)

Place: Quebec (Quebec)  
 Date : December 01, 2021

(President)

## APPENDIX A: QED ATTENUATOR CALIBRATION PROCEDURE

The QED attenuators can be user-calibrated. The calibration procedure is relatively simple. First make measurement without the attenuator, then with the attenuator. The ratio of these measurements will be your correction. This procedure is suitable at any wavelength.

### **When using an oscilloscope**

Divide the joulemeter voltage output by the calibration sensitivity we provide to calculate the energy reading.

To use this procedure at a wavelength other than the wavelength stated on the calibration certificate, you must first manually adjust the sensitivity value (of the calibration certificate) with the wavelength correction multiplier from the Personal Wavelength Correction certificate. Use this wavelength-adjusted sensitivity to calculate the energy readings used in the procedure that follows.

### **When using a Gentec-EO monitor**

The *Attenuator* setting in the *Measure mode* must not be checked. That is, it must be off, otherwise you cannot access the wavelength menu window. You need this window to input the wavelength that you are calibrating at (see monitor manual). The *Attenuator* setting should also be checked off if you are redoing a calibration at the same wavelength as stated on joulemeter calibration certificate.

### **Procedure**

Step 1: Setup your joulemeter to measure the energy of your pulsed laser. If you are working at a wavelength other than the calibrated spectral range, adjust the sensitivity of your joulemeter for that wavelength. Make sure that the energy level is below the detector's damage threshold and your laser still has good stability.

Step 2: Apply energy for a few minutes to warm up the detector. This will reduce any thermal bias.

Step 3: Measure the energy level without the attenuator. To reduce random uncertainty, you should average a number of shots. We recommend at least one hundred shots. This should reduce random errors by a factor of 10. (Square root of "n" assuming Gaussian distribution).

Step 4: Install the attenuator. Without changing the laser settings, measure the energy level by averaging the same number of shots. All laser settings must be the same as Step 3 (including beam size and position on the detector).

Step 5: Repeat the first measurement (Step 3) to make sure that nothing changed during the procedure to invalidate the calibration. A change larger than the uncertainty of your measurements means that something in the laser or environment changed. You can add this to your  $\pm$  uncertainty when you use the attenuator or try to stabilize the laser and environment and begin again with Step 3.

The correction multiplier for the MAESTRO and an oscilloscope will be given by:

$$T_f = \frac{\text{Reading without attenuator}}{\text{Reading with attenuator}} \quad (\text{No units})$$

Now use this calibration factor in the correction menu for the QED when using it at the wavelength established in Step 1.

## APPENDIX B: WEEE DIRECTIVE

### RECYCLING AND SEPARATION PROCEDURE FOR WEEE DIRECTIVE 2002/96/EC

This section is used by the recycling center when the detector reaches its end of life. Breaking the calibration seal or opening the monitor will void the detector's warranty.

The complete detector contains

- 1 detector with cable or DB15.
- 1 calibration certificate
- 1 electronic PCB (INTEGRA option)
- 1 plastic enclosure (INTEGRA option)

### SEPARATION

Paper: Calibration certificate

Wires: Detector cable

Printed circuit board: inside the DB15, no need to separate (less than 10 cm<sup>2</sup>). Inside the INTEGRA enclosure, no need to separate (less than 10 cm<sup>2</sup>).

Aluminum: Detector casing

Plastic: INTEGRA enclosure

# LEADER IN LASER BEAM MEASUREMENT SINCE 1972



POWER & ENERGY METERS



BEAM PROFILING



THZ MEASUREMENT

## CANADA

445 St-Jean-Baptiste, Suite 160  
Quebec, QC, G2E 5N7  
CANADA

T (418) 651-8003  
F (418) 651-1174

[info@gentec-eo.com](mailto:info@gentec-eo.com)

## UNITED STATES

5825 Jean Road Center  
Lake Oswego, OR, 97035  
USA

T (503) 697-1870  
F (503) 697-0633

[info@gentec-eo.com](mailto:info@gentec-eo.com)

## JAPAN

Office No. 101, EXL111 building,  
Takinogawa, Kita-ku, Tokyo  
114-0023, JAPAN

T +81-3-5972-1290  
F +81-3-5972-1291

[info@gentec-eo.com](mailto:info@gentec-eo.com)

## CALIBRATION CENTERS

- 445 St-Jean-Baptiste, Suite 160  
Quebec, QC, G2E 5N7, CANADA
- Werner von Siemens Str. 15  
82140 Olching, GERMANY
- Office No. 101, EXL111 building,  
Takinogawa, Kita-ku, Tokyo  
114-0023, JAPAN