

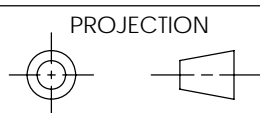

**PINOUT TOP VIEW**

NOTES:  
 1- DIMENSIONS IN mm  
 2- REFER TO DETECTOR SPECIFICATIONS  
 FOR OPTICAL APERTURE

**IMPORTANT:**  
 THIS DOCUMENT  
 IS PROPERTY OF  
 GENTEC ELECTRO-  
 OPTICS, IT CANNOT  
 BE DISTRIBUTED, USED  
 OR REPRODUCED IN  
 WHOLE OR IN PART  
 WITHOUT EXPRESS  
 WRITTEN AUTHORIZATION



REF.	REVISION	DATE	VER	APP	
TOLERANCE DEC. $\pm$ FRAC. $\pm$ ANGLE $\pm$ $\sqrt{\quad}$					
APP.	LAYOUT DRAWING				
VER.	(TO5)				
— Ronald VH	QS (1,2,3,5)				
DATE	2011/02/25	SK-9113		A4	
	4:1	1 OF 2			

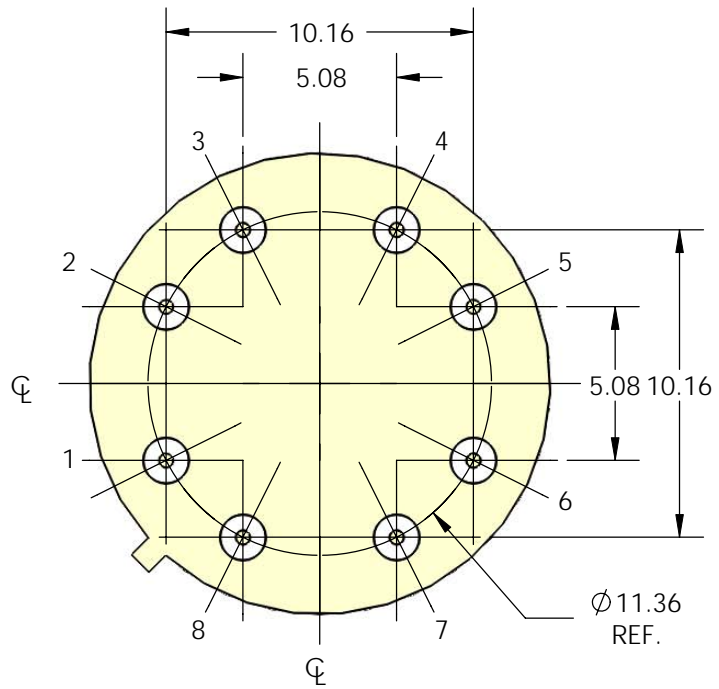
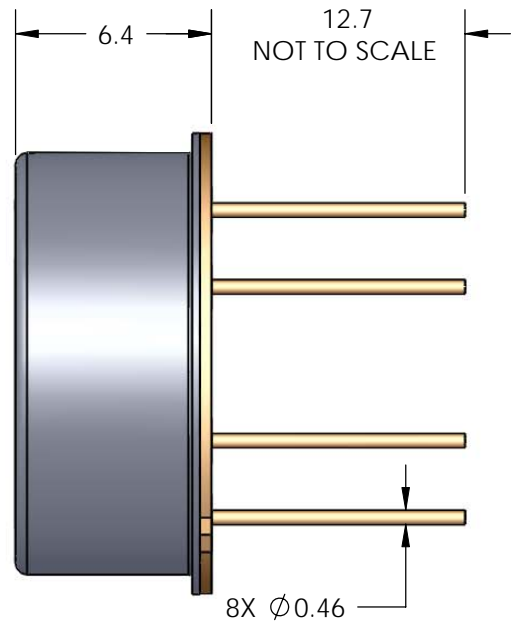
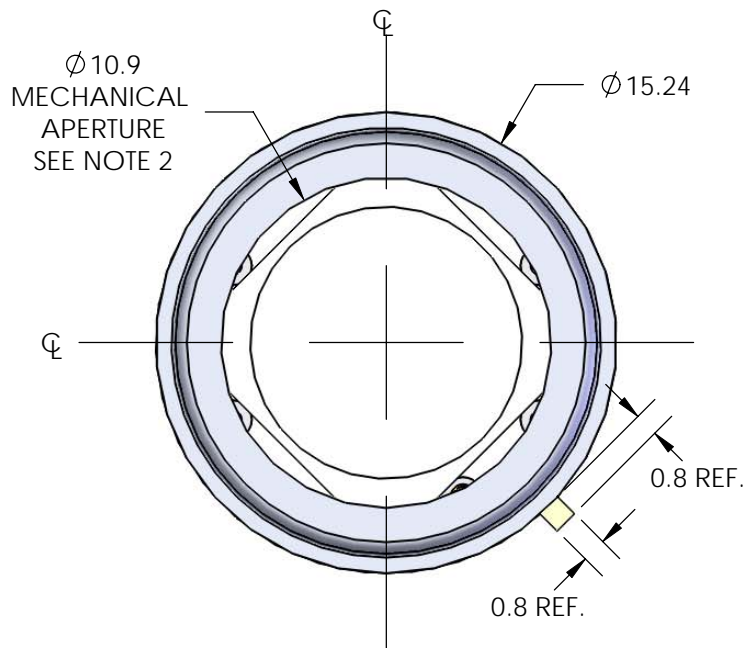

NOTES:  
 1- DIMENSIONS IN mm  
 2- REFER TO DETECTOR SPECIFICATIONS  
 FOR OPTICAL APERTURE

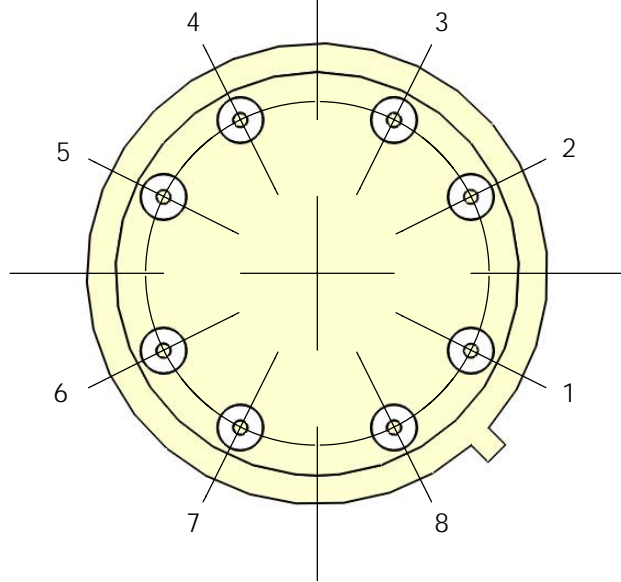

**PINOUT TOP VIEW**

**IMPORTANT:**  
 THIS DOCUMENT  
 IS PROPERTY OF  
 GENTEC ELECTRO-  
 OPTICS, IT CANNOT  
 BE DISTRIBUTED, USED  
 OR REPRODUCED IN  
 WHOLE OR IN PART  
 WITHOUT EXPRESS  
 WRITTEN AUTHORIZATION

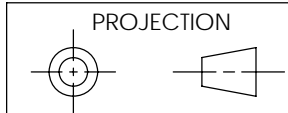

REF.	REVISION	DATE	VER	APP
TOLERANCE				
DEC.	±			
FRAC.	±			
ANGLE	±			
APP.		LAYOUT DRAWING (TO8) QS (9)		
VER.				
	Ronald VH			
DATE	2011/02/25	<b>SK-9113</b>		
	4:1			
		2 OF 2		<b>A4</b>