

**FRONT VIEW, UP25N...**

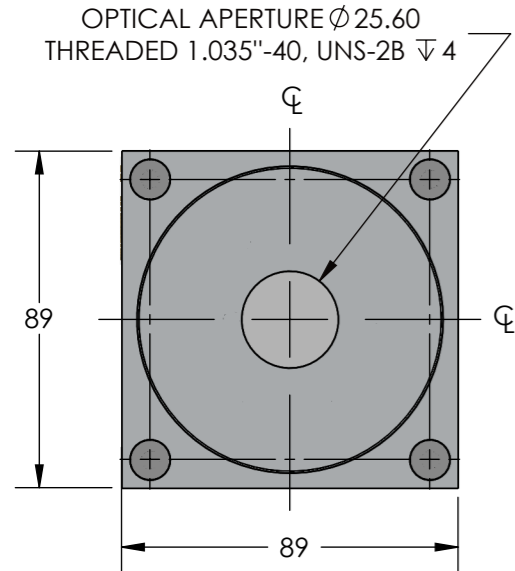

**UP25N-40S**

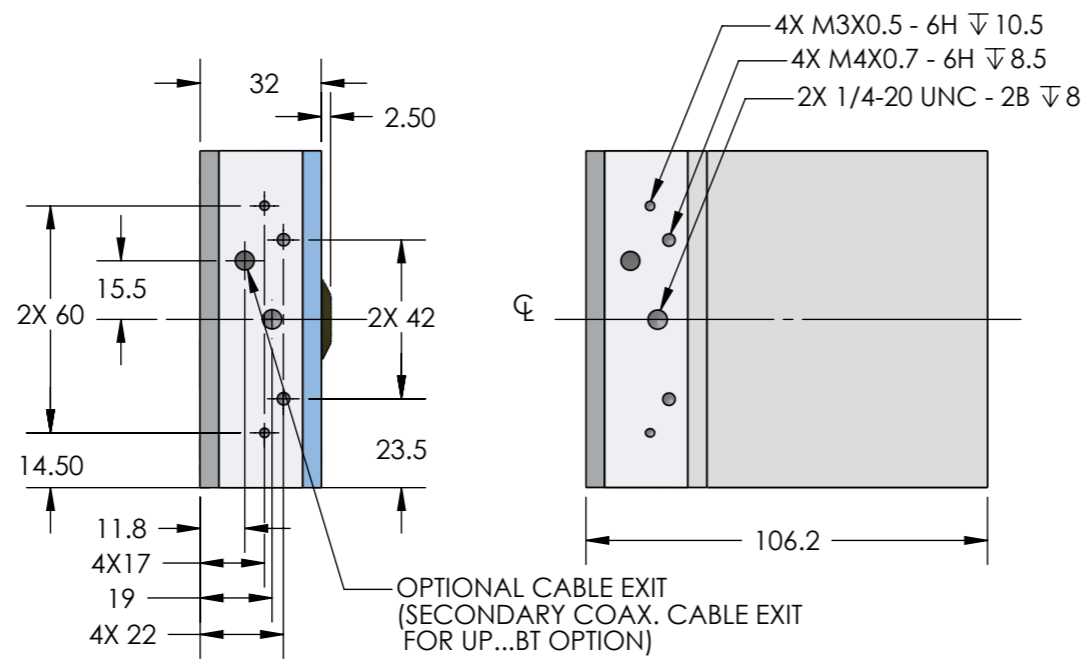

**UP25N-100H**

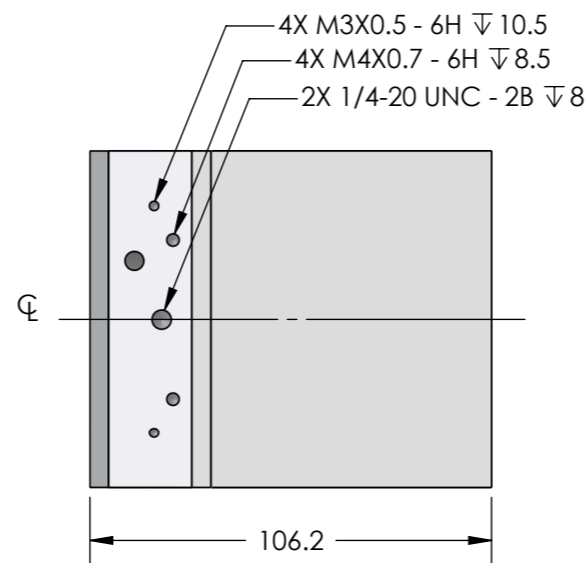

**UP25N-250F**

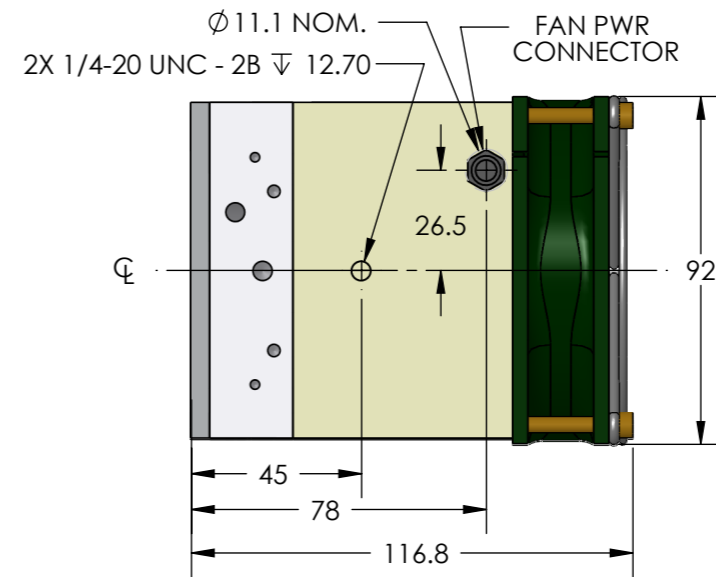

**UP25N-300W**

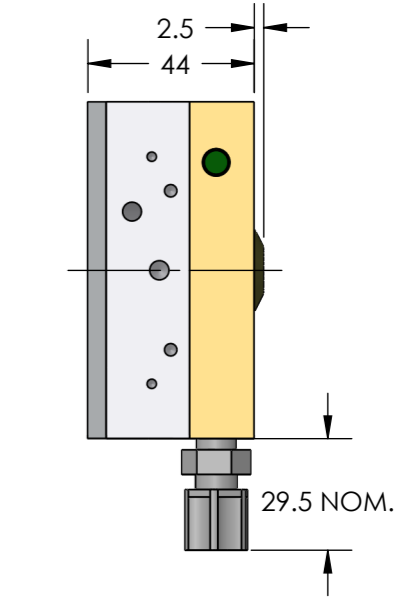

**STANDARD CABLE EXIT**

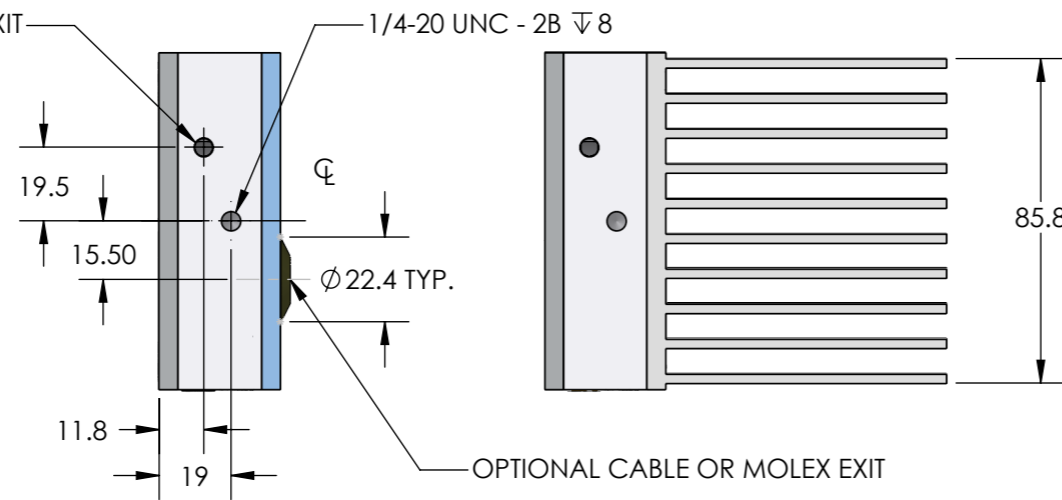

**2.3 NOM.**

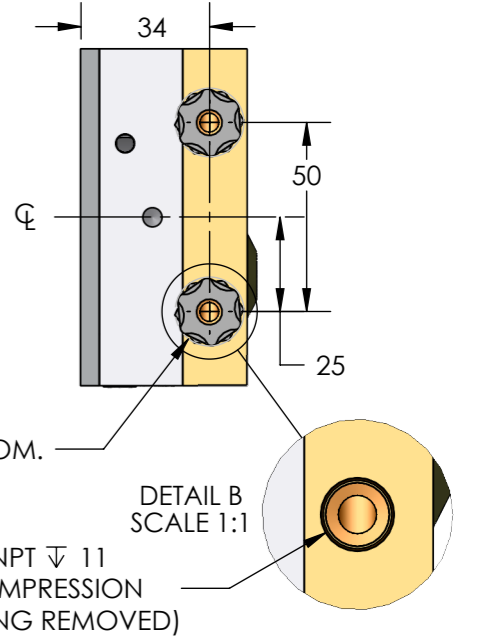
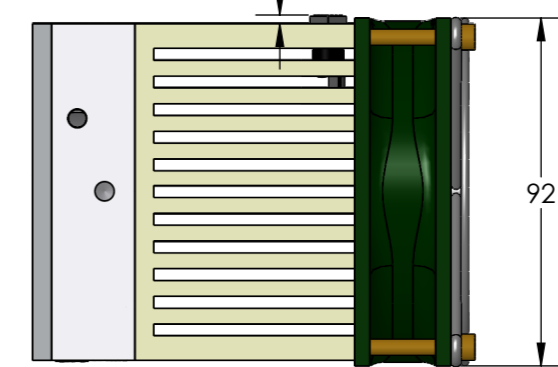

- NOTES:**  
 1- DIMENSIONS IN mm  
 2- FASTENER LENGTH = 27mm + THICKNESS OF CUSTOMER SUPPLIED MOUNT  
 3- WATTMETER MUST BE FASTENED FROM THE FRONT IN ORDER TO SUPPORT THE BODY AND THE REAR COVER OR HEATSINK.

4X 10-24 UNC- 2B ∇ 5  
 SEE NOTES 2 & 3

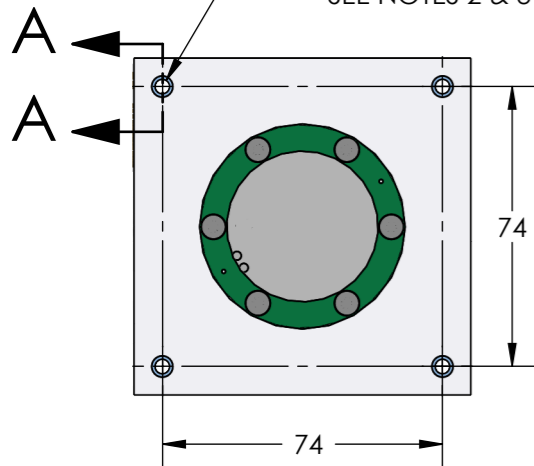

REAR COVER ONLY IS THREADED  
 CUT A-A  
 SCALE 1 : 2

**OPTIONAL UP25N...-MT-B MOLEX CONNECTOR PIN OUT**

- (1) SIGNAL OUT
- (2) SUPPLY 12 VDC
- (3) GROUND / SHIELD
- (4) N/A

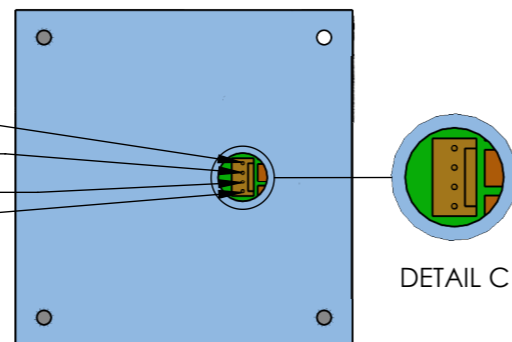

**IMPORTANT:**  
 THIS DOCUMENT IS PROPERTY OF GENTEC ELECTRO-OPTICS, IT CANNOT BE DISTRIBUTED, USED OR REPRODUCED IN WHOLE OR IN PART WITHOUT EXPRESS WRITTEN AUTHORIZATION

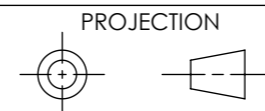

ST 2024-05-17

E	SEE PAGE 2 FOR DETAILS				
REF.	REVISION	DATE	VER	APP	
TOLERANCE					
DEC.	±				
FRAC.	±				
ANGLE	±				
APP.					
VER.					
<b>gentec-EO</b>					
LAYOUT DRAWING					
UP25N...					
DATE	22/10/2003				
DOMINYK ROY					
1:2					
<b>SK-8474</b>				<b>A3</b>	
1 OF 2					

**FRONT VIEW, UP25N...**

OPTICAL APERTURE  $\phi 25.60$   
 THREADED 1.035"-40, UNS-2B  $\nabla 4$

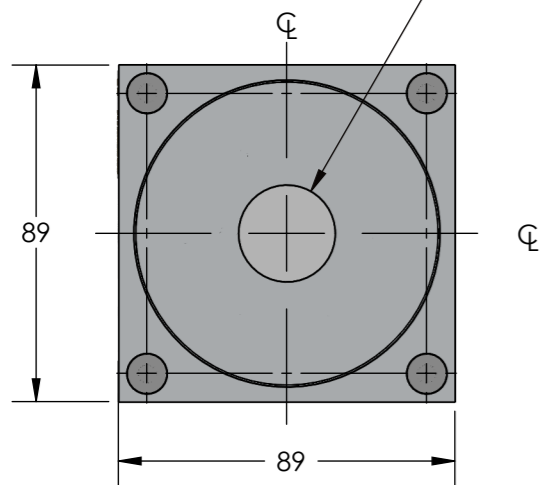

**UP25N-xxxDI**

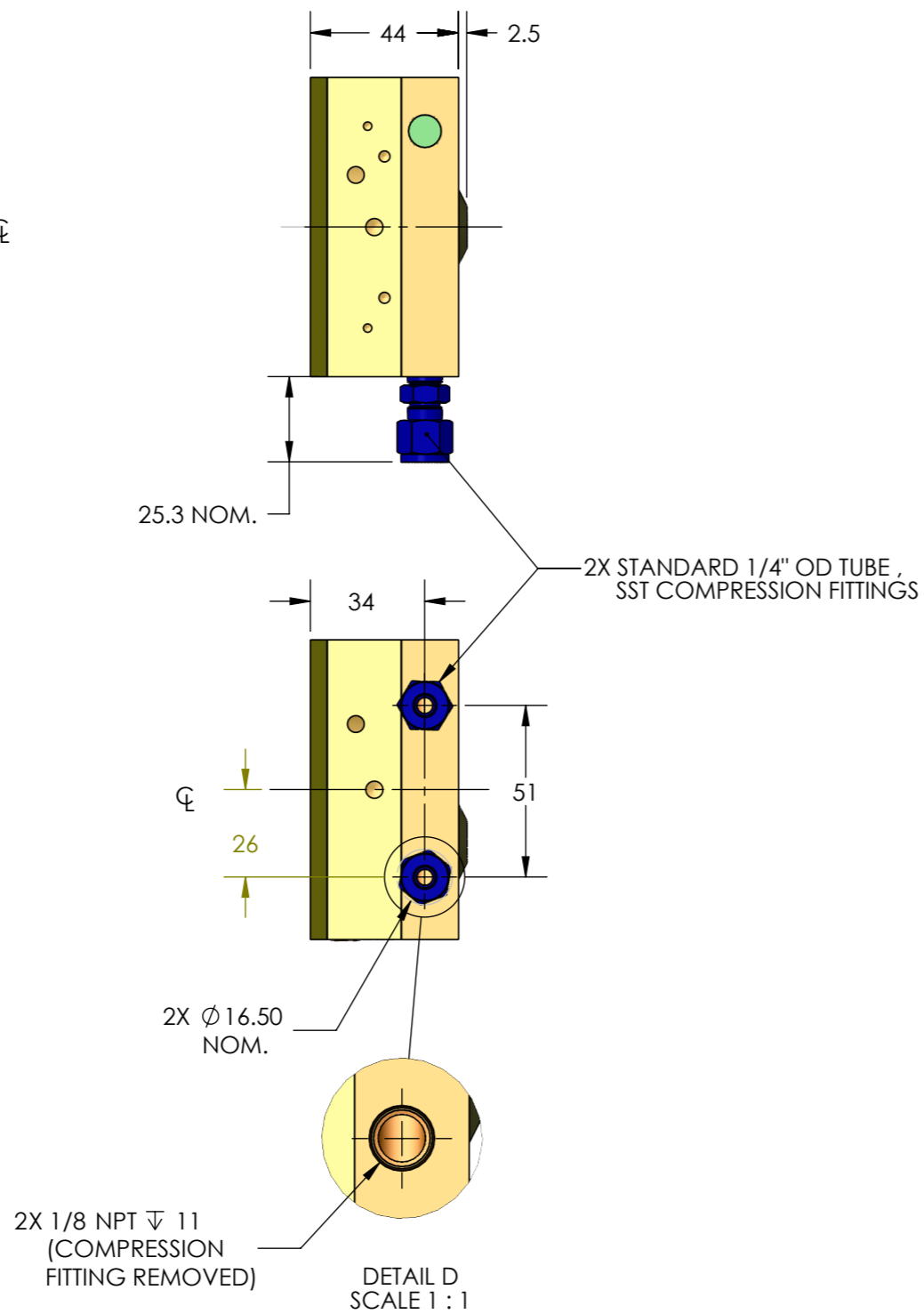

2X 1/8 NPT  $\nabla 11$   
 (COMPRESSION  
 FITTING REMOVED)

DETAIL D  
 SCALE 1 : 1

NOTES:  
 1- DIMENSIONS IN mm  
 2- SEE P1 OF 2 FOR OTHER DETAILS

**IMPORTANT:**  
 THIS DOCUMENT  
 IS PROPERTY OF  
 GENTEC ELECTRO-  
 OPTICS, IT CANNOT  
 BE DISTRIBUTED, USED  
 OR REPRODUCED IN  
 WHOLE OR IN PART  
 WITHOUT EXPRESS  
 WRITTEN AUTHORIZATION

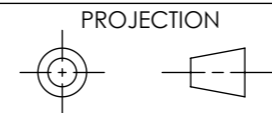

REF.	REVISION	DATE	VER	APP
E	APERTURE THREAD MODIFIED	2024-05-17	ST	LR
D	MINOR CORRECTION	2024-02-27	ST	
C	APERTURE THREAD ADDED	11/12/16	RVH	
B	NOMENCLATURE CORR. DI VERSION	11/08/17	RVH	
A	UP2x... DI VERSION ADDED TO P2 OF 2	25082006	RVH	

TOLERANCE	
DEC.	$\pm$
FRAC.	$\pm$
ANGLE	$\pm$
	$\sqrt{\quad}$



APP.  
 VER.  
 DOMINYK ROY

LAYOUT DRAWING  
 UP25N...

DATE 22/10/2003  
 1:2

SK-8474 2 OF 2 A3