

NOTES:
 1- DIMENSION IN mm
 2- TOTAL WEIGHT = 6.71Kg
 3- ND FILTERS: 0.5, 1.0, 2.0
 4- FOCAL LENS INCLUDED:
 FOCAL DISTANCE: 200mm, 250mm, 300mm
 5- MAX LENGTH TRAVEL:
 FROM FOCAL LENS TO CAMERA SENSOR: 587.3 mm
 6- USE ONLY WITH USB CABLE INCLUDED.
 P.S.: WILL NOT WORK WITH STANDARD USB CABLE

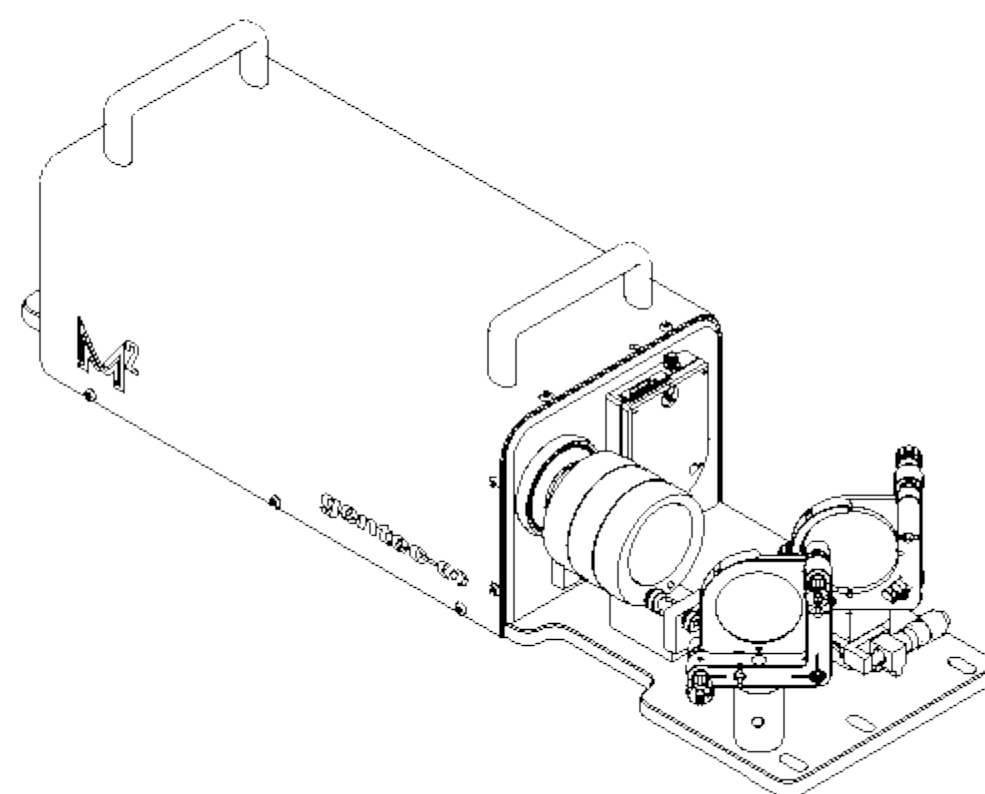

IMPORTANT:
 THIS DOCUMENT IS PROPERTY OF GENTEC ELECTRO-OPTICS, IT CANNOT BE DISTRIBUTED, USED OR REPRODUCED IN WHOLE OR IN PART WITHOUT EXPRESS WRITTEN AUTHORIZATION

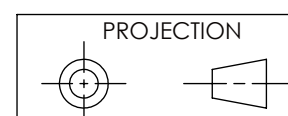

ML 2024-04-24
 BT 2024-04-17
 JP 2024-03-26
 MAS 2024-02-28
 ST 2024-02-26

A	MINOR CORRECTION	2024-02-26	ST	MAS	LR	
REF.	REVISION	DATE	VER	APP		
TOLERANCE						
DEC.	±					
FRAC.	±					
ANGLE	±					
APP.	LAYOUT DRAWING					
VER.	BEAMAGE M2					
S. BOUCHARD		BEAMAGE				
DATE	2017/11/15	SK-9769				
1:2		A2				